

## The Evaluation of Crashworthiness of Vehicles with Forming Effect

### Authors:

Hyunsup Kim\*, Sungoh Hong\*, Seokgil Hong\*, Hoon Huh\*\*

\*KIA Motors, Kwangmyung, Korea

\*\*Korean Institute of Science and Technology, Science Town, Daejeon, Korea,

### Correspondence:

Hyunsup Kim  
Passenger Car Body Engineering Team 3, KIA Motors  
781-1 Soha-dong  
Kwangmyung-Shi, Kyungki-do  
Korea

Tel: +82-31-369-7183  
Fax: +82-31-369-7184  
e-mail: kimhs@kia.co.kr

### Keywords:

Crashworthiness analysis, Forming effects,  
Finite element analysis, Full frontal crash, Offset frontal crash

### **ABSTRACT**

This paper is concerned with a crash analysis for vehicle structures considering forming effects. The properties of formed vehicle structures have been effected and changed by such as work hardening, non-uniform thickness distribution resulted from the forming process. The crash analysis of vehicle structures with the forming effects leads to different results from those without such effects. In this study, the forming effects of the front side member assembly of vehicle structures are considered. The plastic strain and thickness distribution from the simulation results of the forming process have been used as an initial condition for crash analysis. The crash analysis of a full vehicle structure has been performed with those forming effects, and the results are compared to those without the forming effects. The deceleration pulse and deformation from the results are calculated and investigated in order to identify forming effects. Analysis results demonstrate that crash analysis of vehicle structures with forming effects can be more effective for accurate approximation of deceleration pulse and deformation mode.

### **INTRODUCTION**

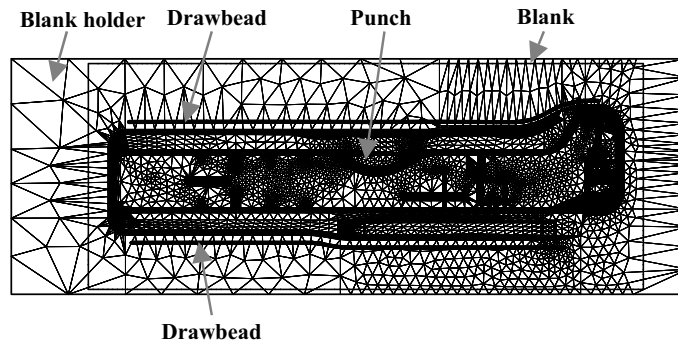
Crash analysis of vehicle structures has been studied to improve reliability for crashworthiness and development of light-weight vehicle. In order to accomplish reliable crash simulation, crashworthiness of vehicle structures should be evaluated considering the effect of stamping and forming as well as the dynamic properties of materials. Material properties of FE model for crash analysis are assumed to be those of raw steel material, in general. However, as most members of vehicle body structure are manufactured by sheet metal forming process, there can be changes in thickness and yield point of the material resulted from the forming process. These changes in material properties are known to affect the crash response significantly. Those studies about crash analysis considering forming effects demonstrate that the crash analysis of vehicle structures should be carried out considering forming effects for the purpose of reliable assessment [1][2][3][4][5][6]. The most of studies about crash analysis with forming effects have been performed for a single component. Therefore, it is need to investigate the behavior of the full vehicle structure according to the forming effects and significance in these changes of material properties for accurate prediction of crash response.

In this paper, forming effects of the front side member assembly of a MPV are considered to evaluate the crashworthiness of the full vehicle. The front side member assembly is a major energy-absorbing component in frontal crash. Non-uniform distributions of the effective plastic strain and the thickness strain are obtained from the forming simulation and used selectively or in combination as the initial condition for crash analysis. Full frontal and 40% frontal offset crash analysis of a full vehicle structure have been performed with the forming effects and the results are compared to those without the forming effects. The crash analysis results also are compared with test results to investigate the performance of prediction in crash response. It is noted from the results that forming effects have a significant influence on the structural response of the crash analysis and should be considered for the accurate evaluation of the crashworthiness.

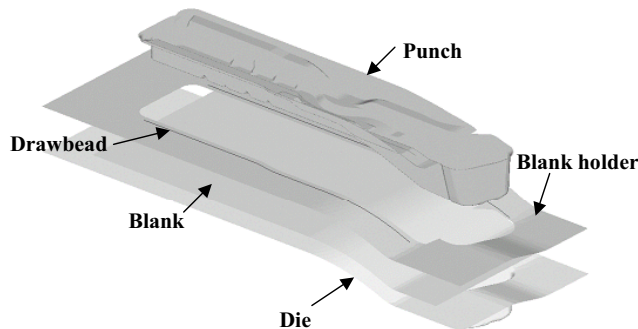
**Forming analysis of the front side member assembly**

A front side member assembly of a MPV considered in this paper is composed of four parts: front side member inner; front side member outer ; reinf front side member-A; reinf front side member-C. The forming histories are calculated with the direct forming analysis for four panels that have great influences on the behavior of the front crash. For the sake of the computational efficiency, the restraining forces of drawbeads in the dies are calculated with an implicit elasto-plastic finite element code, ABAQUS/Standard. The forming analysis is then carried out for the four panels, imposing the calculated restraining forces as boundary conditions of the equivalent drawbead [7][8]. The forming analysis, which is made up of the binder wrap process and the punch forming process, is performed with LS-DYNA. Calculated forming results are applied to the crash simulation as the initial condition.

The punch and die profiles for the finite element analysis of the drawbead forming process are extracted from the geometric data of the tool set as shown in Figure 1 for front side member inner. Drawbeads are employed with the different shape and size according to each panel. The binder wrap analysis as well as the drawing analysis of the drawbead is performed to calculate the restraining force of drawbeads for accurate forming simulation. Calculated equivalent drawbead forces are applied to the forming analysis of the front side member inner.

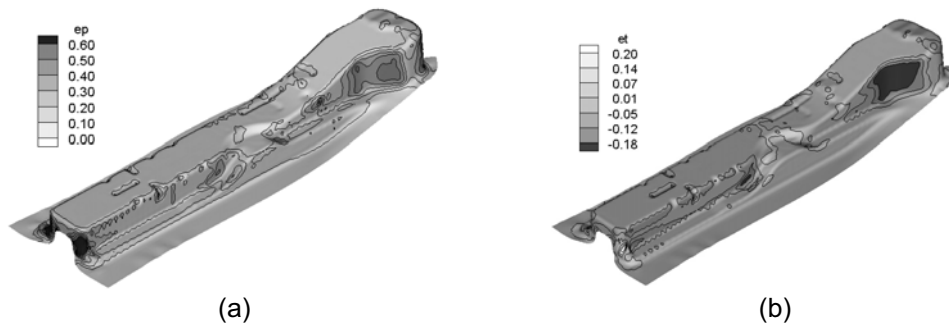


**Figure 1** Location of drawbeads in the sheet metal forming die for a front side member.

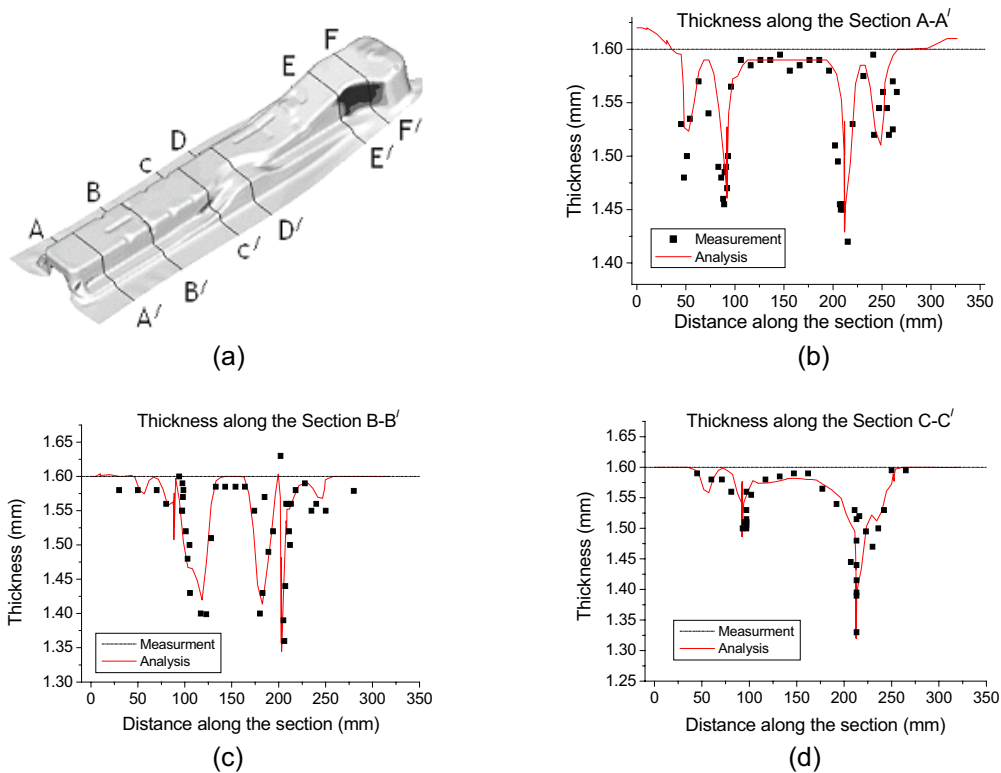


**Figure 2** Initial setting of tools and the blank for the numerical analysis of the front side member inner.

Direct forming analyses have been carried out for four panels of the front side member. The die, the punch and the blank holder are modeled with finite element patches for forming simulation of each panel. Figure 2 shows the tooling system for the analysis of the front side member inner.



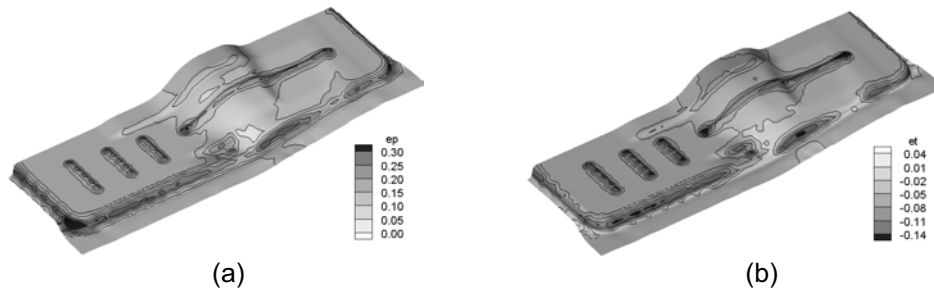
**Figure 3** Final forming results of the front side member inner: (a) effective plastic strain distribution; (b) thickness strain distribution.



**Figure 4** Comparison of thickness distribution of the front side member inner: (a) measured section; (b) section A-A'; (c) section B-B'; (d) section C-C'.

Figure 3 shows the effective plastic strain distribution and the thickness distribution in the front side member inner after forming simulation. The thickness distribution calculated has been compared to that in the real part for the front side member inner. Figure 4 shows the quantitative comparison of the thickness variation along the designated line between the real product and the finite element simulation result. The figures show very close coincidence between the measured results and the calculated results. The comparison fully demonstrates that the result from finite element forming simulation of the front side member inner is highly reliable and can be applied to the crash analysis as the initial condition without distorting real crash behavior. Figure 5 shows the effective plastic strain distribution and the thickness distribution in the front side member outer after forming simulation.

Forming analyses of other panels were also carried out with the same procedures in order to obtain the effective plastic strain distribution and thickness distribution as the forming history that is to be considered as forming effects in the crash simulation. Distributions of the effective plastic strain and the thickness were mapped into new finite element mesh systems for the crash simulation.



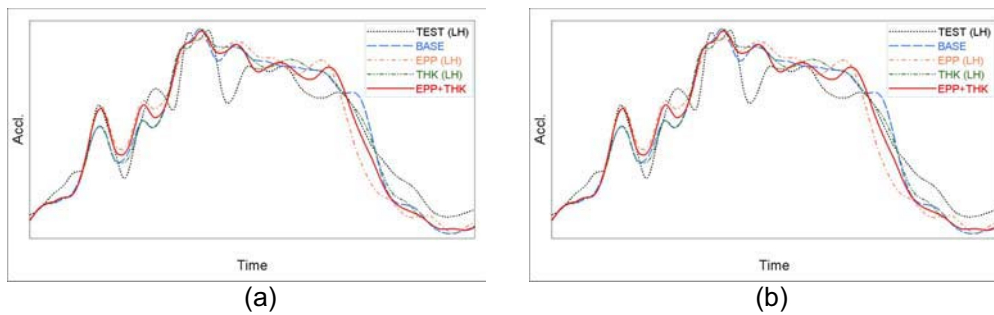
**Figure 5** Final forming results of the front side member outer: (a) effective plastic strain distribution; (b) thickness strain distribution.

### Crash Analysis

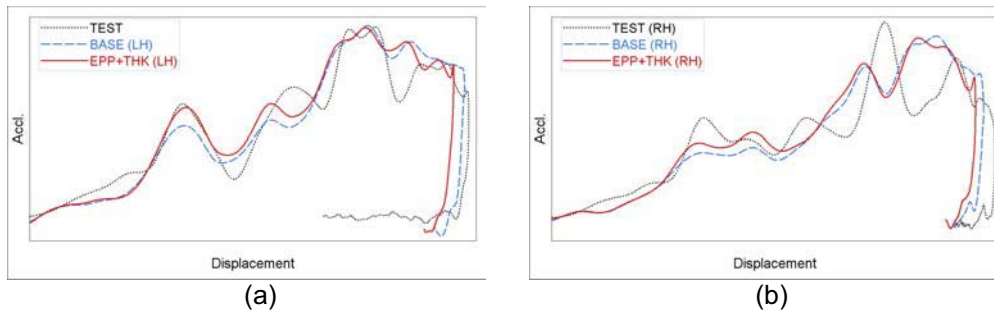
Crash simulation of a full car has been performed to evaluate the influence of forming effects on crash response. The forming results obtained from the previous work were used as an initial condition for the crash analysis with forming effects. The following four types of models have been constructed to investigate the influence of the forming effects.

- 1) Original raw material properties used model
- 2) Thickness initialized model
- 3) Effective plastic strain initialized model
- 4) Combined model (Thickness and Effective plastic strain initialized)

The thickness and effective strain distribution resulted from the forming analysis were mapped into FE model for crash analysis using the option 'INCLUDE\_STAMPED\_PART' implemented in LS-DYNA. Crash simulation has been performed under full frontal (NCAP mode) and 40% frontal offset (EURO-NCAP mode) crash condition. The original model with raw material properties has been correlated with actual test, but there is some difference in initial peak value.



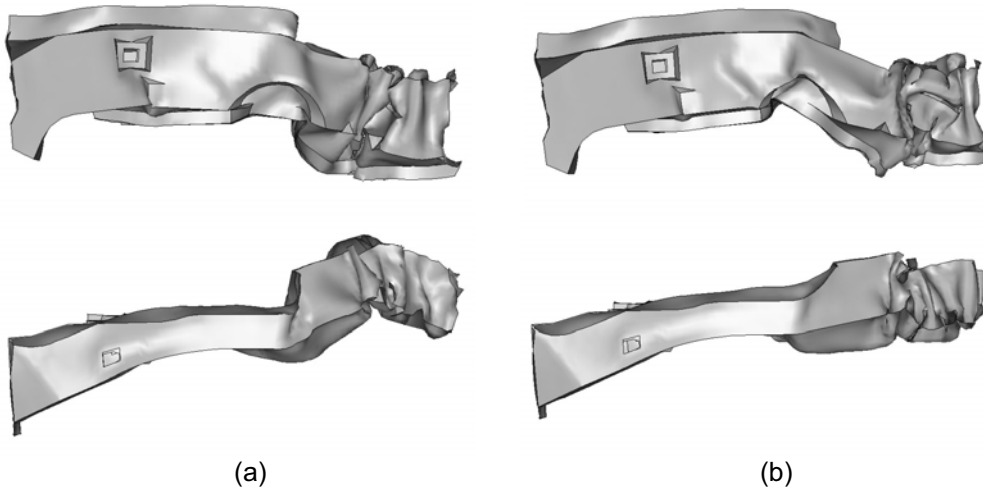
**Figure 6** Comparison of vehicle deceleration with respect to time plot for 35mph full frontal crash: (a) driver-side; (b) passenger-side.



**Figure 7** Comparison of vehicle deceleration with respect to displacement curve for 35mph full frontal crash: (a) driver-side; (b) passenger-side.

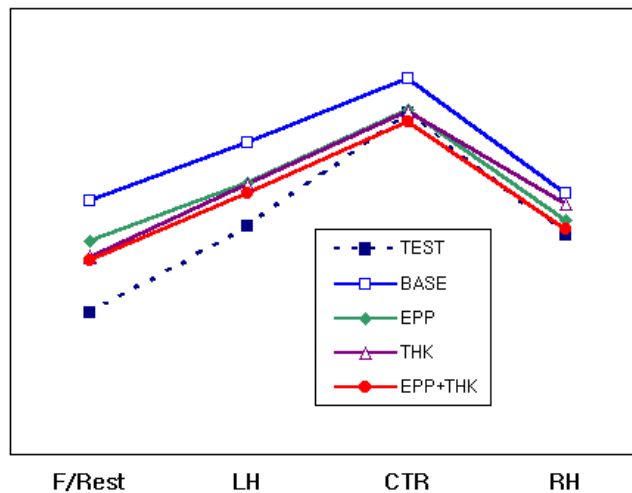
Figure 6 shows the comparison of vehicle deceleration pulses obtained from the full frontal crash simulation and test result. The difference in deceleration pulse between analysis results with and without forming effects appears at the initial stage, because forming effects were considered only for the front side member assembly that affects the initial stage of crash response. The simulation result of thickness initialized model is almost identical to that of the original model without forming effects. However, it appears that the initial peak value of deceleration for the effective plastic strain initialized model has increased. The combined model (thickness and effective plastic strain initialized model) also shows similar feature in deceleration pulse and good agreement with test result.

According to the increase of initial peak value, the deceleration pulse at the latter stage decreases early compared to the result without forming effects. And it can be confirmed through the deceleration-displacement curve that the dynamic deformation is decreased in this case as shown in Figure 7. On the other hand, the simulation result of the effective strain initialized model shows relatively stiffer response. Figure 8 shows the comparison of final deformed shape in case of the original model and the combined model. There is remarkable difference in collapse mode due to the work hardening effect. The simulation result without forming effects shows excessive bending mode. On the other hand, the initialized effective strain distribution restrains the weak part from bending excessively and introduces stable axial collapse mode that is similar to the test result.



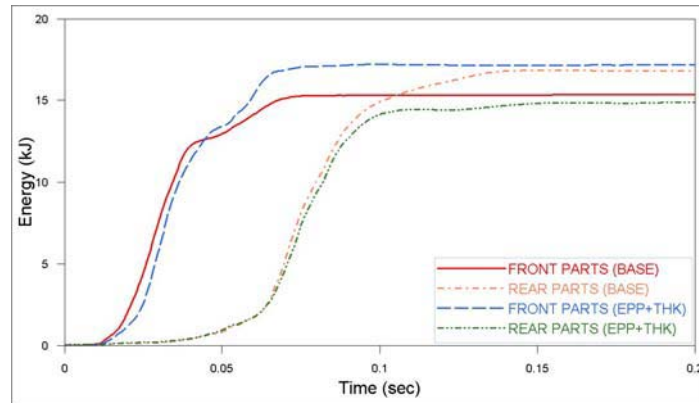
**Figure 8** Deformed shapes of the front side member assembly for 35mph full frontal crash: (a) without forming effects; (b) with forming effects.

For the 40% frontal offset crash, toeboard intrusions have decreased in case of the simulation results with forming effects compared to the case without forming effects as shown in Figure 9. The thickness and effective plastic strain initialized combined model of all results with forming effects shows most reliable result with actual test.



**Figure 9** Comparison of toeboard intrusion for 40% offset crash.

Figure 10 shows the comparison of internal energy of front side member assembly and its rear parts including center floor for the original model and the combined model. The internal energy of the front side member assembly (front parts) for the combined model has increased compared to the original model, and internal energy of rear parts has decreased. This change in energy absorption seems to be resulted from the increased yield strength of the front side member assembly due to the work hardening effect and concentration of deformation at the reinforcement in the assembly.



**Figure 10** Comparison of internal energy for front side member assembly and its rear components for 40% offset crash.

This increased energy absorption of front parts is supposed to induce decrease of deformation and energy absorption of rear parts. It is demonstrated that the best result of all simulations has been obtained for the case of the thickness and effective plastic strain initialized combined model. Furthermore, it is noted that work hardening effect is the most dominant factor of the forming effects.

### Summary and Conclusions

Crash analysis of a vehicle structure has been carried out considering the forming effect in order to evaluate the crashworthiness investigating the deceleration characteristics and deformation mode. The forming analysis of the front side member assembly has been carried out to obtain the distribution of the thickness and the effective plastic strain that was considered as the initial condition of the crash analysis. The crash analysis results considering forming effects were compared with those without forming effects. Crash response of the structure with forming effects was far stiffer and has shown more similar results with actual tests. The comparison demonstrated that the effective plastic strain was dominant in calculation of the deceleration characteristic and deformation mode. Forming effects have been considered only for front side member assembly that affects crash response at the initial stage in full frontal crash. Therefore, deceleration characteristics have shown considerable difference at the initial stage and the result considering forming effects has shown good agreement with test result. For deformation under offset crash, the crash response considering forming effects has shown more reliable results. It is fully demonstrated that the forming effects need to be considered for more accurate and effective evaluation of crashworthiness.

### References

1. Kellicut, A., Cowell, B., Kavikondala, K., Dutton, T., Iregbu, S. and Sturt, R. (1999) "Application of the Results of Forming Simulation in Crash Models", proc. NUMISHEET'99, pp. 509-514.
2. Dutton, T., Iregbu, S., Sturt, R., Kellicut, A., Cowell, B. and Kavikondala, K. (1999) "The Effect of Forming on the Crashworthiness of Vehicles with Hydroformed Frame Siderails", SAE 1999-01-3208.



3. Mikami, H., Suzuki, H., Ishizawa, M and Matsuoka, Y. (1999) "Crash Simulation Considered Influence of Stamping", Proc. HANPAM'99, Seoul, Korea, pp. 187-200.
4. Lee, S.-H., Han, C.-S., Oh, S.-I. and P. Wriggers, "Comparative Crash Simulations Incorporating the Results of Sheet Forming Analyses," Engineering Computations, Vol. 18, No. 5/6, pp. 744-758, 2001.
5. Kim, K. P. and Huh, H. (2003) "Collapse Analysis of Auto-Body Structures Considering the Effect of Fabrication", Key Engineering Materials, Vols. 233-236, pp. 737-742.
6. Huh, H., Kim, K. P., Kim, S. H., Kim, H. S. and Hong, S. K. (2003) "Crashworthiness of Front Side members in an Auto-body Considering the Fabrication Effect", 12<sup>th</sup> IPC on Automotive Engineering, T27.
7. Huh, H and Han, S. S. (1995) "Numerical Simulation of Rectangular Cup Drawing Process with Drawbeads", Proc. NUMIFORM'95, Itacha, U.S.A., pp. 723-728.
8. Meinders, T., Geijselers, H. J. M. and Huétink, J. (1999) "Equivalent Drawbead Performance in Deep Drawing Simulations", Proc. NUMISHEET' 99, Besancon, France, pp. 243-248.
9. HALLQUIST, J.O., TSAY, C.S. (2001) "LS-DYNA vs. 960 Users Manual", Livermore Software Technology Corp., Livermore.

