

eta/DYNAFORM

DFE Training Manual

An LS-DYNA Based Sheet Metal Forming
Simulation Solution Package

Version 5.5

Engineering Technology Associates, Inc.
1133 E. Maple Road, Suite 200
Troy, MI 48083

Tel: (248) 729-3010
Fax: (248) 729-3020
Email: support@eta.com

eta/DYNAFORM team
August 2006

Engineering Technology Associates, Inc. All rights reserved ©1998-2006.

FOREWORD

The concepts, methods, and examples presented in this text are for illustrative and educational purposes only, and are not intended to be exhaustive or to apply to any particular engineering problem or design.

This material is a compilation of data and figures from many sources.

Engineering Technology Associates, Inc. assumes no liability or responsibility to any person or company for direct or indirect damages resulting from the use of any information contained herein.

TABLE OF CONTENTS

INTRODUCTION.....	1
PREPARATION OF DFE	2
Import the model and save the database.....	2
Start eta/DYNAFORM 5.5	2
Import the file.....	2
Save the database.....	4
Edit parts	4
Auto-Meshing the Surfaces.....	5
Check and Repair Meshes	8
Tipping.....	9
Symmetry Definition	11
Inner Fill.....	14
Outer Smooth.....	16
CREATE BINDER.....	17
CREATE ADDENDUM.....	21
Create Master Profile	21
Insert Addendum	23
Smooth Addendum	25
Create Addendum Surface.....	26
BINDER TRIMMING.....	28
UNFOLD FLANGE	31

INTRODUCTION

The eta/DYNAFORM-DFE module, Die Face Engineering, has been developed to generate Die Face (including Addendum and Binder) to support early stage die design. The functions provided in the eta/DYNAFORM-DFE module includes

- Flange Unfolding
- Group surface and create mid surface from a solid
- Automatic filleting for sharp edges
- Automatic filling of holes, boundary fill and outer boundary smooth
- Automatic tipping and adjusting of drawing direction
- Repair the topology of mesh
- Automatic and interactive generation and modification of a binder
- Automatic and interactive generation and modification of outer and inner addendum
- Morphing part or die geometries
- Re-engineering
- Drawbar creation
- Full parameterization

PREPARATION OF DFE

Import the model and save the database

Start eta/DYNAFORM 5.5

For Unix/Linux users, enter the command “**df55**” (default) from a UNIX/LINUX shell. For PC users, double click the **eta/DYNAFORM 5.5 (DF55)** icon from the desktop. After starting **eta/DYNAFORM**, a default database **Untitled.df** is created.

Import the file

1. From the menu bar, select **DFE→PREPARATION→IMPORT** to open the IMPORT FILE dialog box illustrated in Figure 1.
2. Next, click the drop-down button of File Type to select “**IGES (*.igs;*.iges)**”. Then, go to the training input files located in the CD provided along with the eta/DYNAFORM installation. Locate the data file: **hood_inner.igs**.
3. Use your mouse cursor to select the data file, following by clicking the **Import** button. Now, the model illustrated in Figure 2 is displayed on the display area.
4. Exit the **DFE Preparation** dialog box.

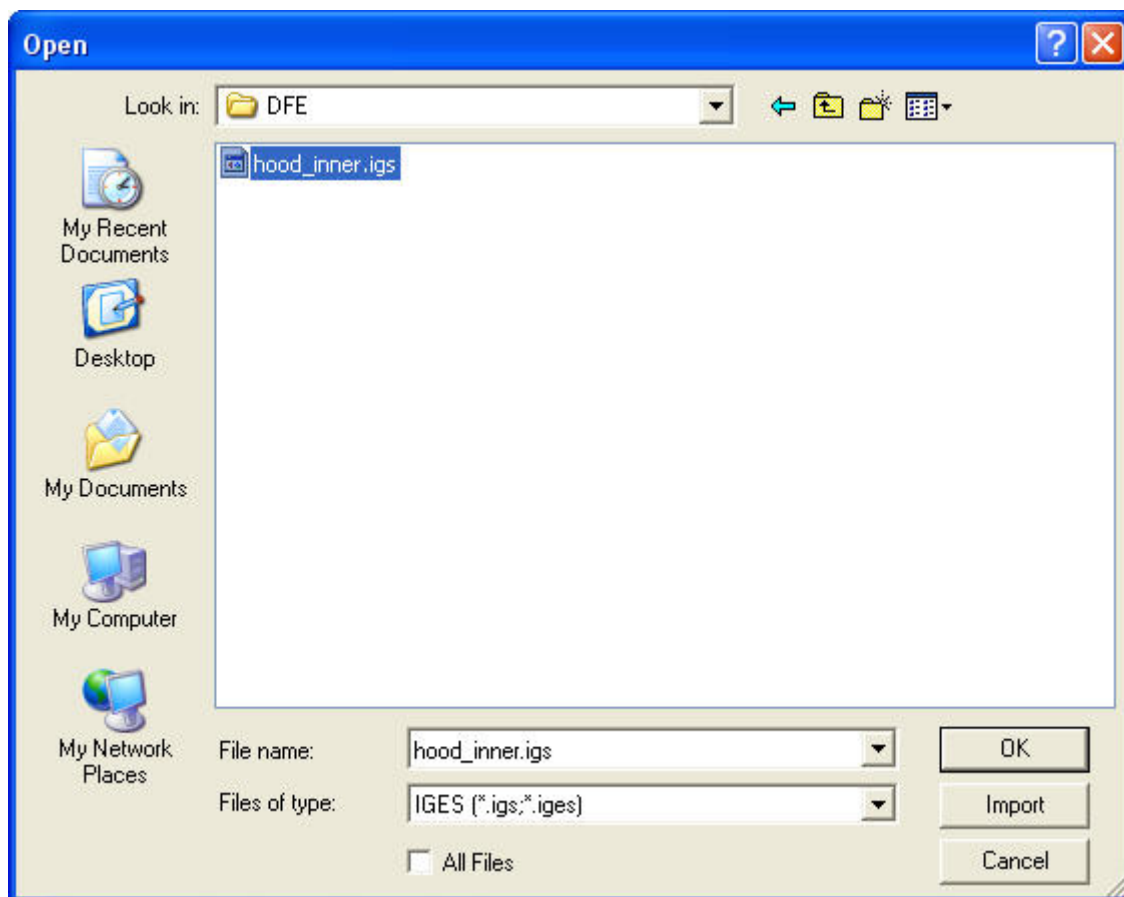

Figure 1 Import file dialog box

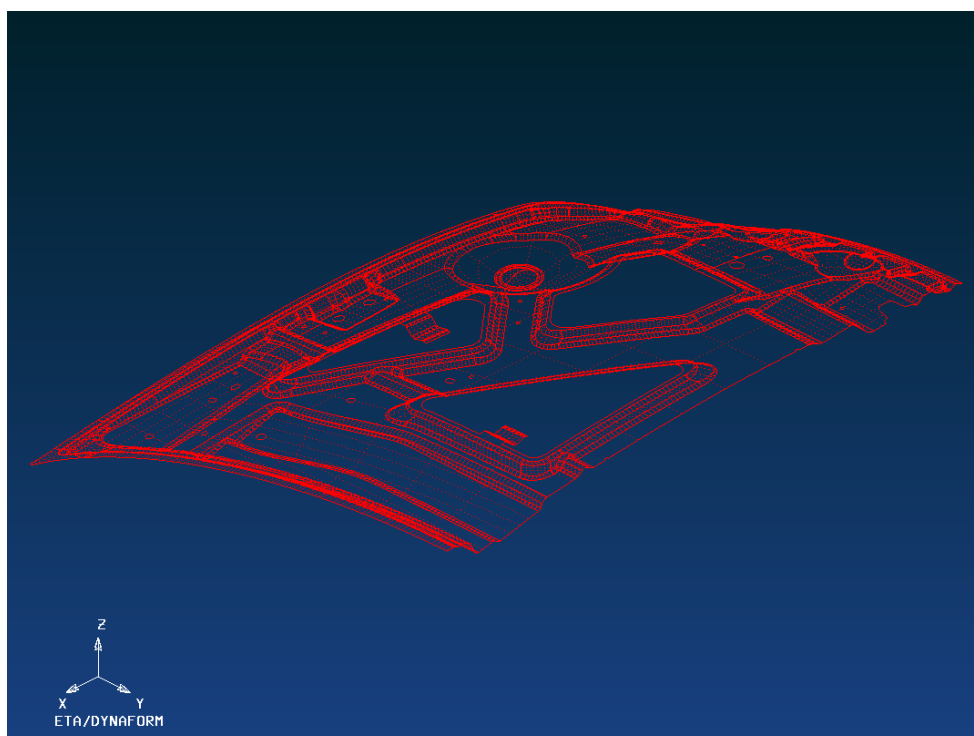

Figure 2 Illustration of model

Save the database

1. Click **Save** icon from the **Icon bar** to open the **SAVE AS** dialog box, as illustrated in Figure 3.
2. Next, type in **hood_inner** in the input data field of File Name, following by clicking **Save** button to save the database.

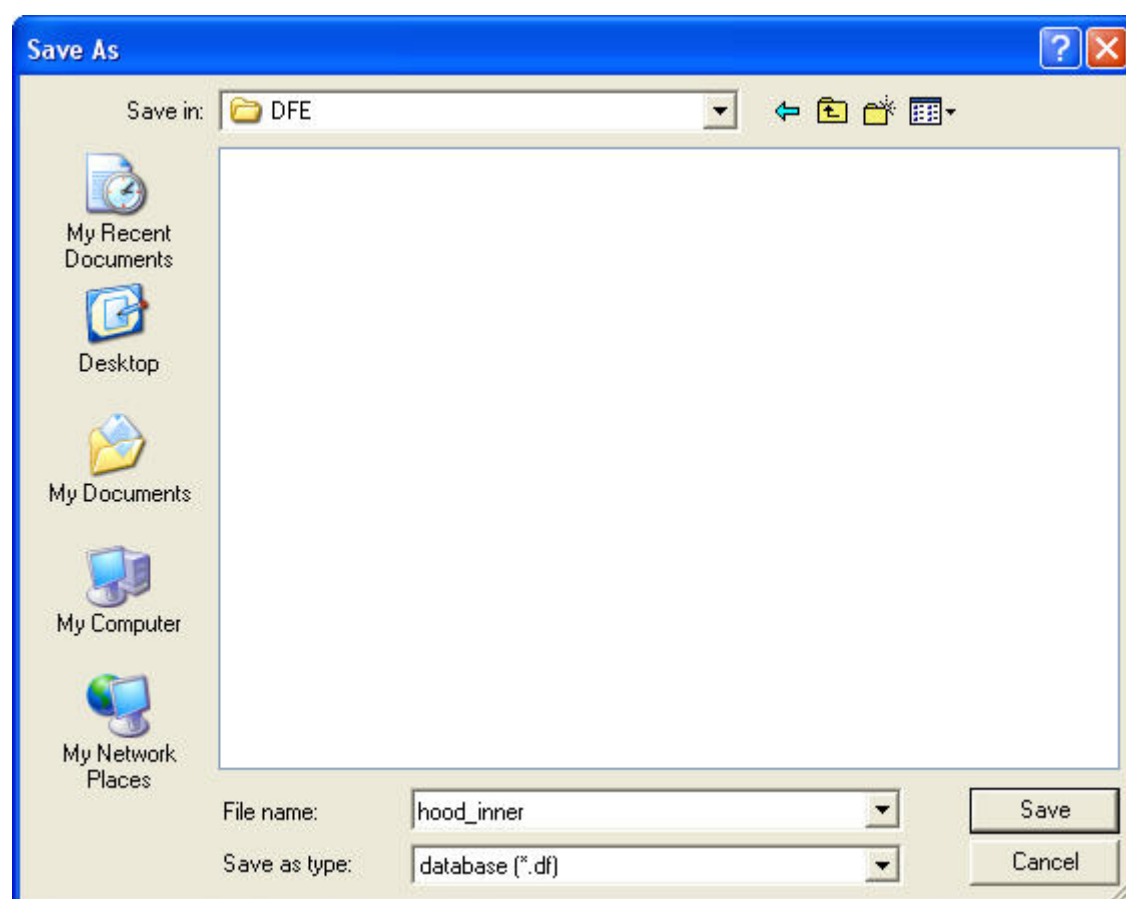

Figure 3 Save As dialog box

Edit parts

1. From the menu bar, select **Parts→Edit** to display the **Edit Part** dialog box, as illustrated in Figure 4.
2. Place your mouse cursor at the data input field of Name, following by double clicking the left mouse button to highlight the part name **C001V000**.
3. Then, type in **HOODINN**, following by clicking the **Modify** button to complete the operation

- Click **OK** button to dismiss the **Edit Part** dialog box.

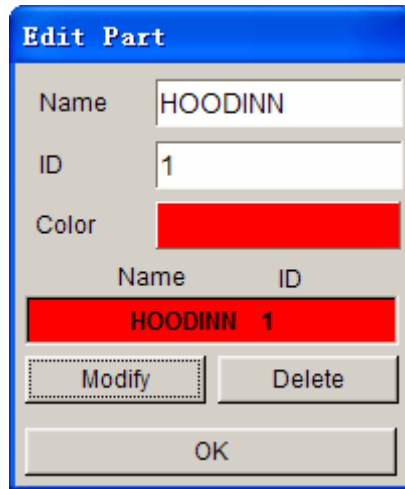

Figure 4 Edit part dialog box

Auto-Meshing the Surfaces

- Select **DFE**→**Preparation** from the menu bar, as illustrated in Figure 5.
- Select **MESH TOOL** function in the **DFE Preparation** dialog box, as illustrated in Figure 6.

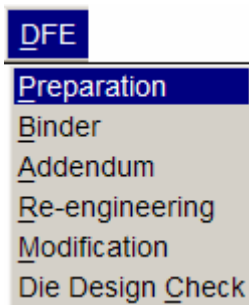

Figure 5 DFE menu

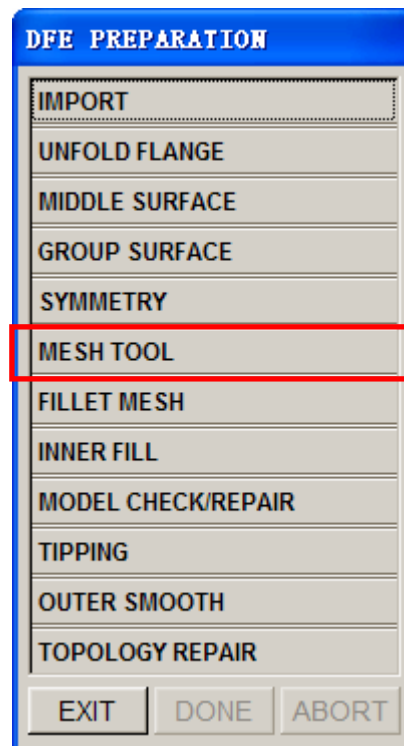

Figure 6 DFE Preparation menu

- The **Surface Mesh** dialog box is displayed. Toggle on the **In Original Part** option, and modify the **Max. Size** as **20**, as illustrated in Figure 7.

Note: Chordal deviation controls the number of elements along the line/surface curvature;

Angle controls the direction of the feature line

Gap Tol. Controls whether two adjacent surfaces are connected.

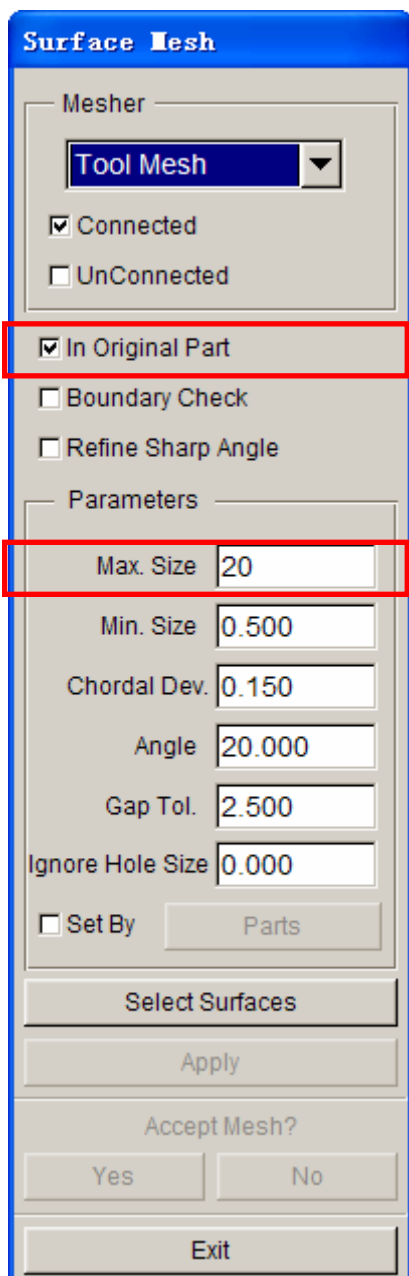

Figure 7 Surface Mesh dialog box

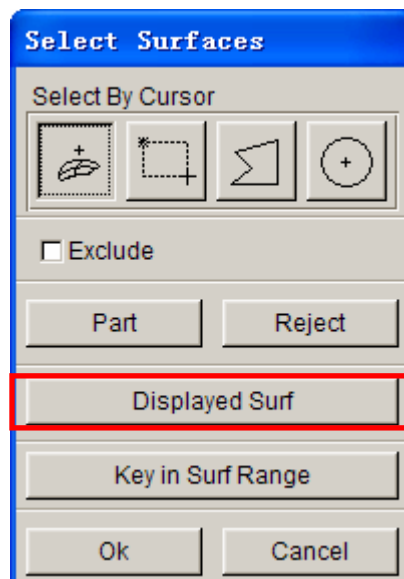

Figure 8 Select Surfaces dialog box

- Click the **Select Surfaces** button to display the **Select Surfaces** dialog illustrated in Figure 8.

5. Click the **Displayed Surf** button to highlight all the surfaces in the display area, as illustrated in Figure 9.
6. Next, toggle on **Exclude** option in **Select Surfaces** dialog box.
7. Use your mouse cursor to select the flange surfaces as circled in Figure 9.
8. Click **Ok** button to exit the **Select Surfaces** dialog box
9. Click **Apply** button to mesh the selected surfaces.
10. The generated mesh is highlighted in white. Click **Yes** button to accept the mesh. Compare the mesh with Figure 10.
11. Click **Exit** to dismiss **Surface Mesh** dialog box.
12. Exit **DFE Preparation** dialog box
13. Save your database.

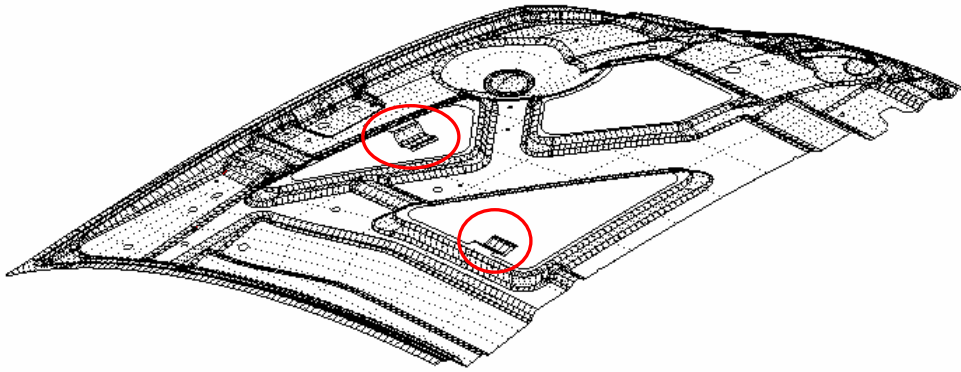

Figure 9 Flange surfaces

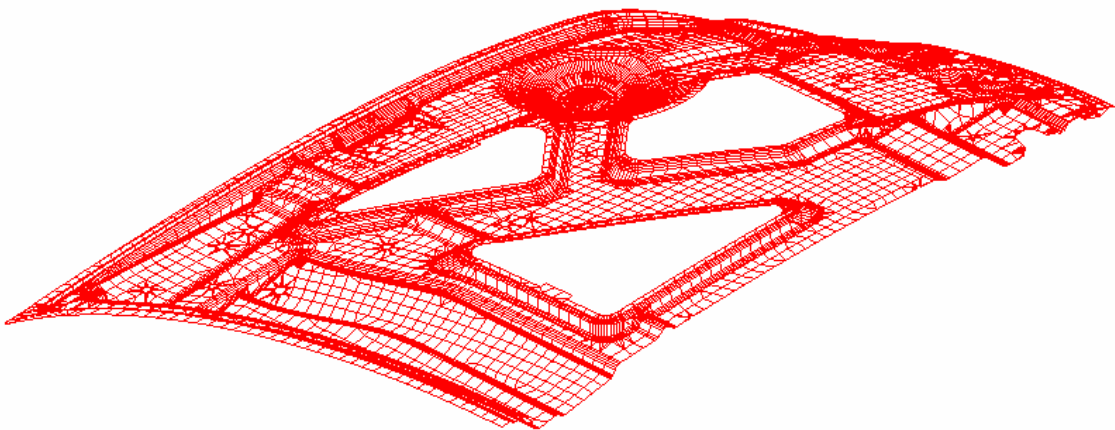

Figure 10 The model after meshing

Check and Repair Meshes

1. Select **DFE→Preparation→MODEL CHECK/REPAIR** to display the **Model Check & Repair** dialog box illustrated in Figure 11.

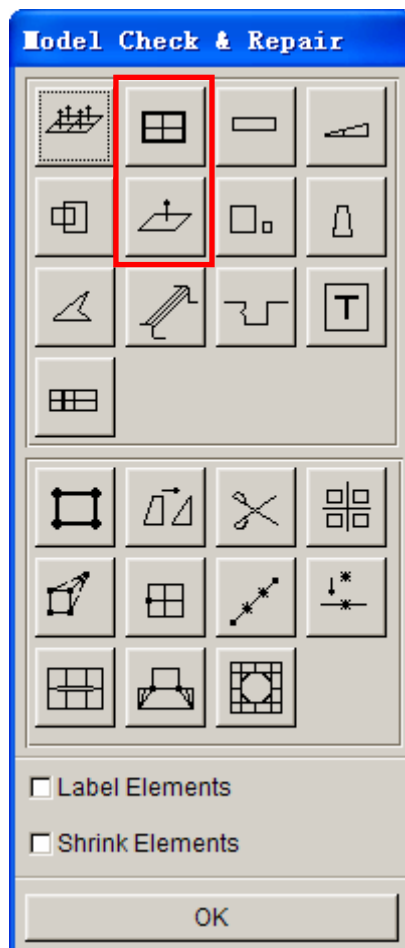

Figure 11 Model Check & Repair dialog box

2. Click **Boundary Display** icon to show the model boundary
3. Then, click **Clear Highlight** icon from the **Icon bar** to remove the highlighted boundary.
4. Click the **Plate Normal** icon to consistency of element normals.
5. Click **Ok** button to exit the **Model Check & Repair** dialog box.

Note: You may use other tools to check and repair the model.

Tipping

1. Select **TIPPING** in the **DFE Preparation** dialog box to display the **Tipping** dialog box illustrated in Figure 12.

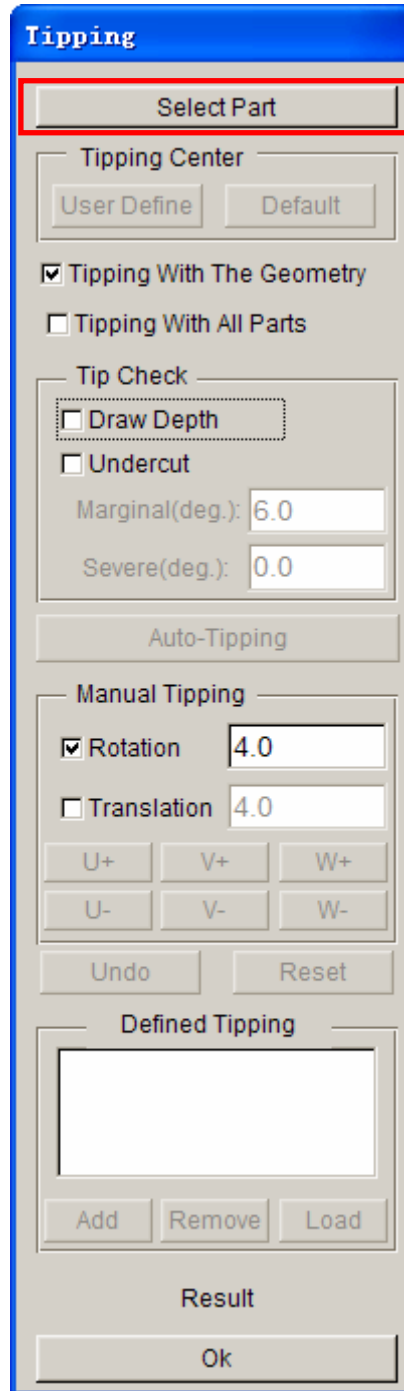

Figure 12 Tipping dialog box

2. Click **Select Part** button to select the part for tipping operation. The Select Part dialog box illustrated in Figure 13 is displayed.

3. Use your mouse cursor to pick the part HOODINN in the **Select Part** dialog box.
4. Click **OK** button to exit the **Select Part** dialog box.
5. Toggle on **Undercut** option in the **Tipping** dialog box to display the undercut contour in the display area, as illustrated in Figure 14.
6. Click **Ok** button to exit the **Tipping** dialog box.

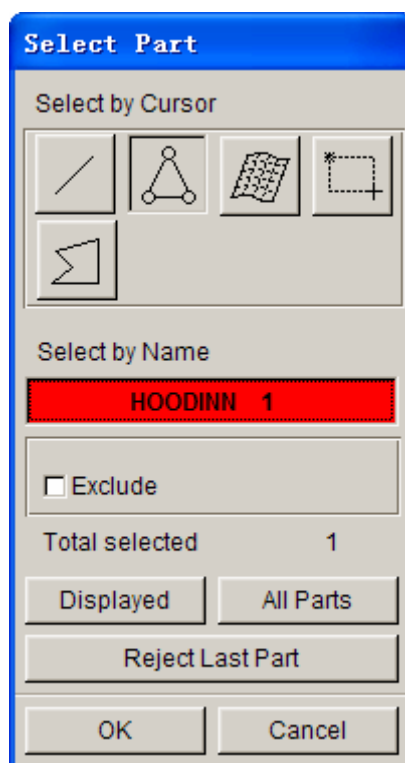

Figure 13 Select Part dialog box

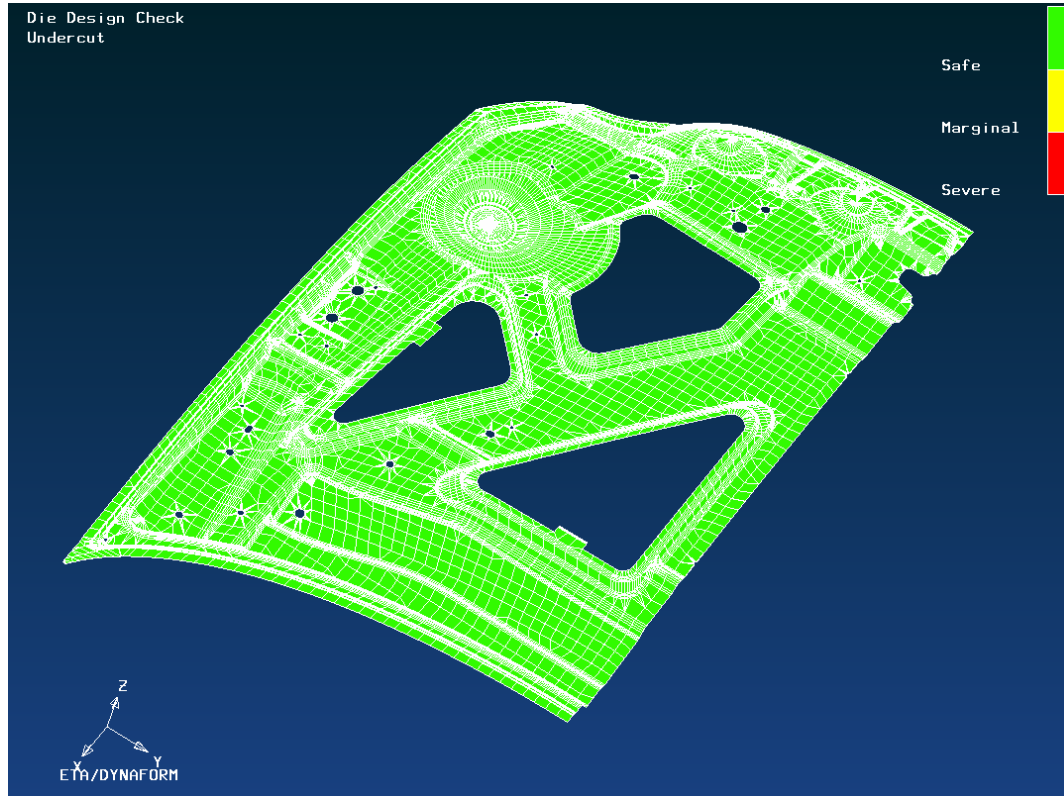

Figure 14 Illustration of Undercut contour display

Symmetry Definition

1. Select **SYMMETRY** function in the **DFE Preparation** dialog box.
2. A **Dynaform Question** dialog box illustrated in Figure 15 is displayed.
3. Click **Yes** to accept current part as Die.
4. The **Symmetry** dialog box illustrated in Figure 16 is displayed.
5. Select **Geometry Type** as Half Symmetry Input
6. Toggle on **two-xy-points** as symmetry type in the **Symmetry** dialog box.
7. Click **Select point(s)** button in the **Symmetry** dialog box to display the **Input Coordinate** dialog box.
8. Select two nodes as illustrated in Figure 17 to define the symmetry plane.

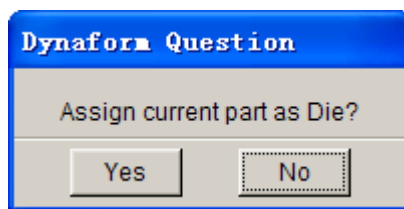

Figure 15 Dynaform Question dialog box

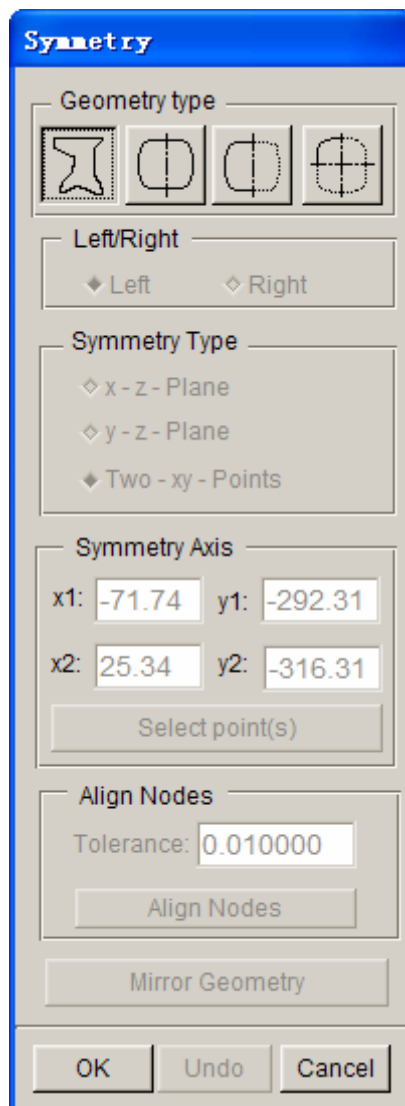

Figure 16 Symmetry dialog box

9. Click **Mirror Geometry** button to display the **Select Part** dialog box.
10. Select **HOODINN** from the Select Part dialog box, following by clicking **Ok** button to exit the dialog box.
11. As illustrated in Figure 19, the other half of the hood inner is mirrored.
12. Click **OK** button to exit the **Symmetry** dialog box.

13. Click **Exit** button to exit the **DFE Preparation** dialog box.
14. Save your database.

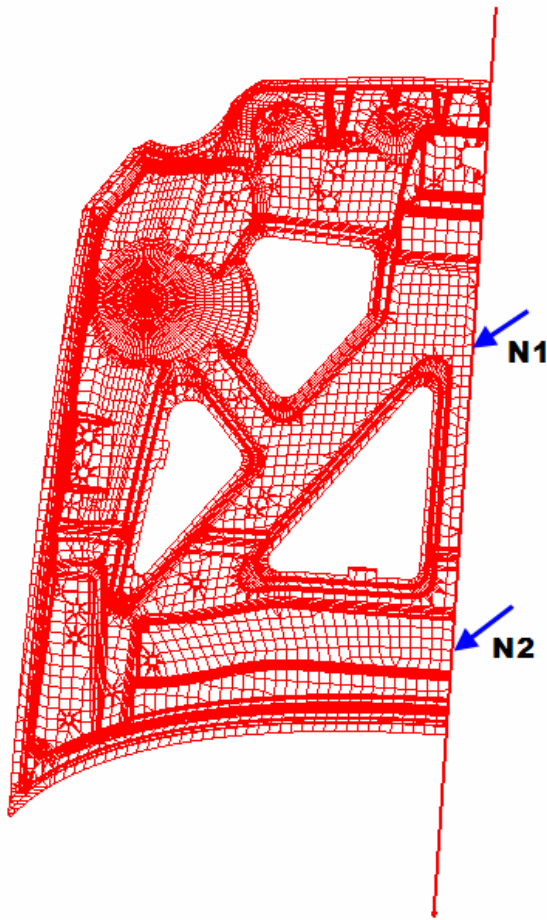

Figure 17 Selected Nodes to define symmetry plane

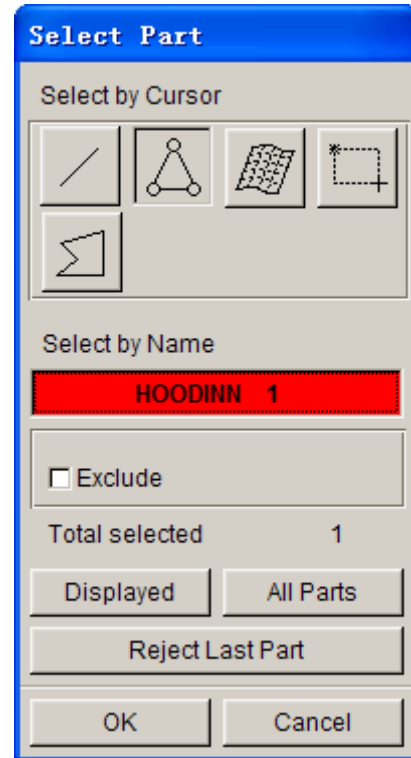

Figure 18 Select Part dialog box

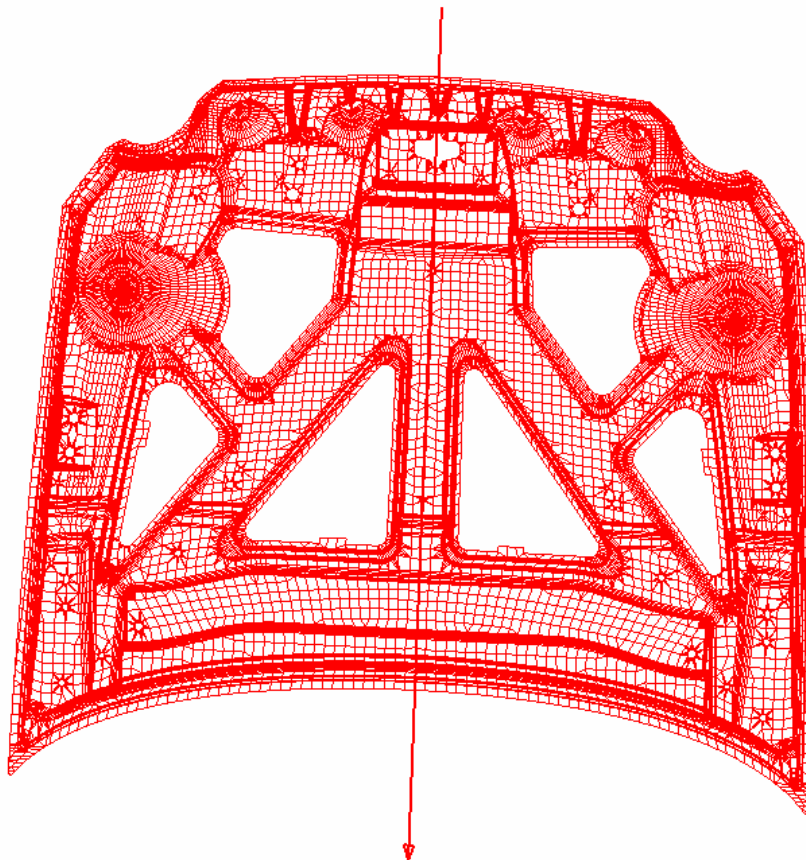

Figure 19 Part mesh after symmetry operation

Inner Fill

1. Select **Parts**→**Create** from the menu bar or use the shortcut key (**Ctrl+P**) to open the **Create Part** dialog box, as illustrated in Figure 20.

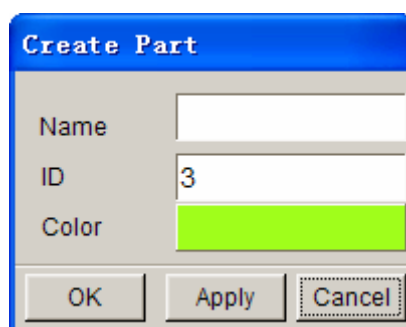

Figure 20 Create Part dialog box

2. Type in **INNFILL** in the data input field of Name.
3. Change the ID to 2, then click **OK** to complete the operation.

4. Select **DFE**→**Preparation** to display the **DFE Preparation** dialog box.
5. Select **INNER FILL** function in the dialog box to display the **Inner Fill** dialog box illustrated in Figure 21.

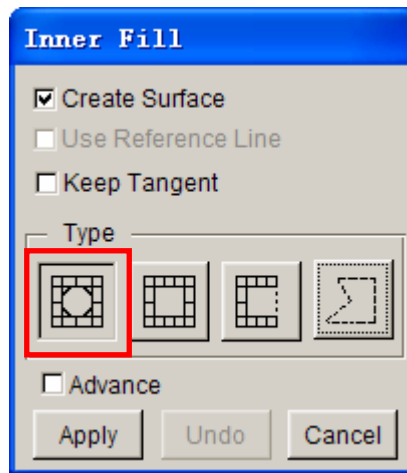

Figure 21 Inner Fill dialog box

6. Select the fill type: **Auto Fill**, following by clicking **Apply** button.
7. Click the middle mouse button to validate the result illustrated in Figure 22.
8. Click **Cancel** button to exit the **Inner Fill** dialog box.

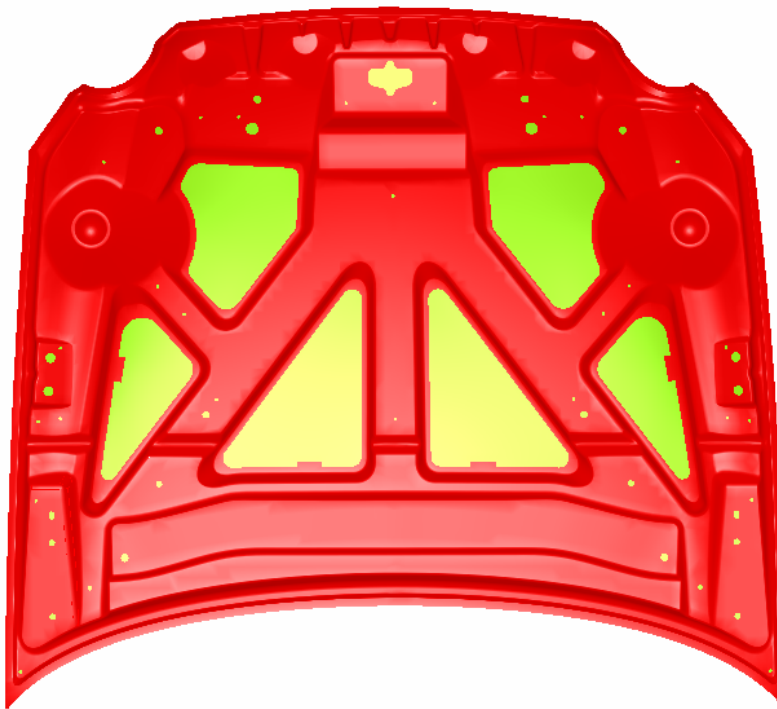

Figure 22 Auto Fill

Outer Smooth

1. Select **OUTER SMOOTH** in the **DFE Preparation** to display the dialog box illustrated in Figure 23.
2. Click **Select Part** button in the **Outer Smooth** dialog box. Select **HOODINN** in the **Select Part** dialog box, as illustrated in Figure 24.
3. Click **OK** button to exit the **Select Part** dialog box.
4. Input the **Roll Radius: 300** (mm).
5. Click **Create Boundary** button. A highlighted boundary line is displayed in the display area.
6. Click **Fill Boundary** button to fill the boundary near the headlamp area of the hood, as illustrated in Figure 25.
7. Click **Exit** button to quit the dialog box.

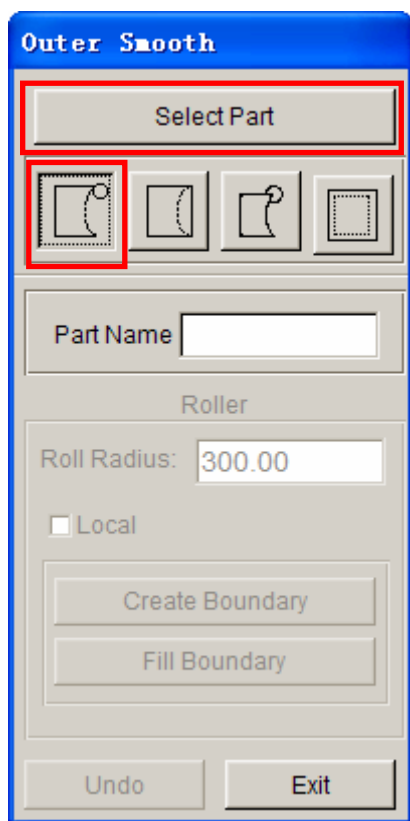

Figure 23 Outer Smooth dialog box

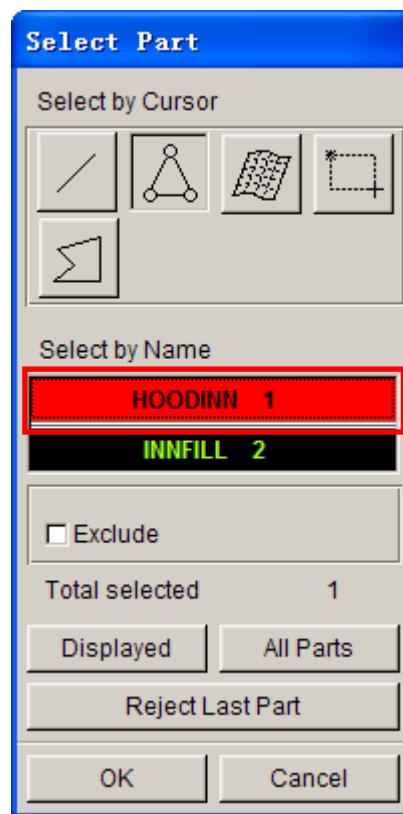

Figure 24 Select Part dialog box

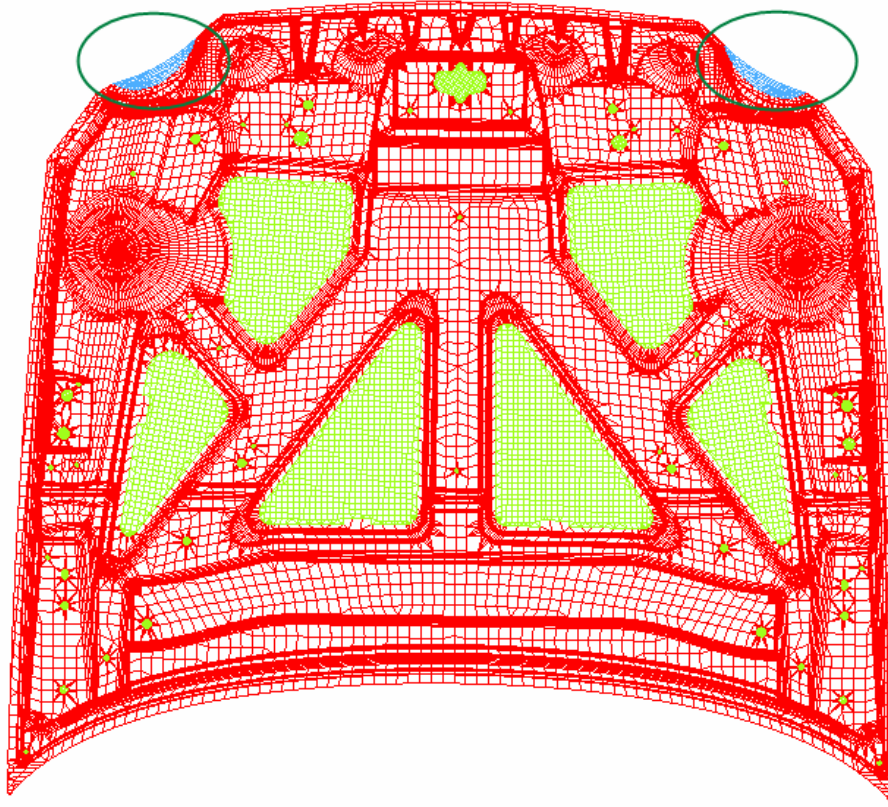

Figure 25 After outer smooth

CREATE BINDER

1. Select **DFE**→**Binder** from the menu bar, as illustrated in Figure 26

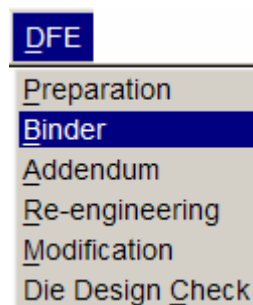

Figure 26 DFE menu

2. Select binder type (flat binder) from the binder dialog box, as illustrated in Figure 27.
3. Input the **Binder Margin: 400**.

4. Click **Define Binder Orientation** following by pressing the middle mouse button. The binder orientation has been defined, as illustrated in Figure 28.

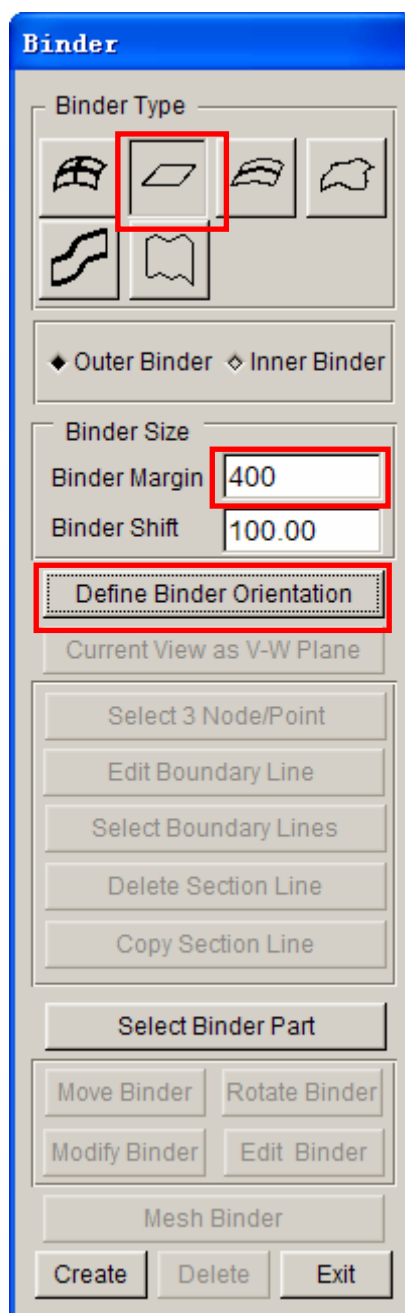

Figure 27 Binder dialog box

5. Click **Create** button at the bottom of the **Binder** dialog box. The flat binder surface has been created as illustrated in Figure 29.
6. Click **Mesh Binder** button to display the **Element Size** dialog box.
7. Input the value of the **Max Size** and **Min Size: 40**, as illustrated in Figure 30.
8. Click **OK** to mesh the binder surface. The binder surface has been meshed, as illustrated in Figure 32

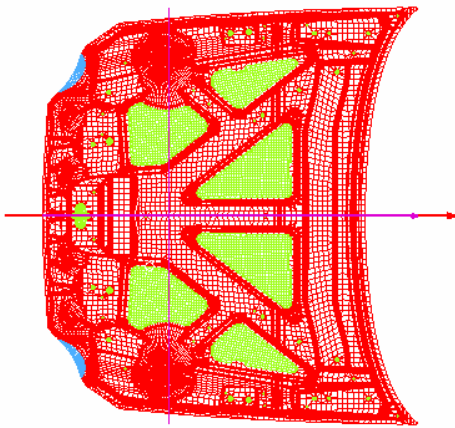

Figure 28 Define binder orientation

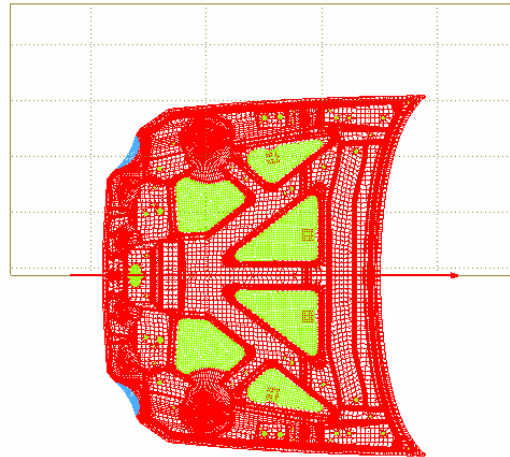

Figure 29 Create flat binder surface

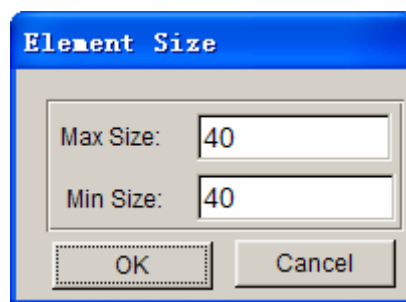

Figure 30 Element Size dialog box

9. Click **Move Binder** button. The **UVW INCREMENTS** dialog box is displayed.
10. Toggle on **W** as move direction and type in **60.00** (mm), as illustrated in Figure 31.
11. Click **Apply** button to move the binder.
12. Click **Ok** button to exit the **UVW INCREMENTS** dialog box.
13. Click **Exit** button to quit the **Binder** dialog box.
14. Save your database.

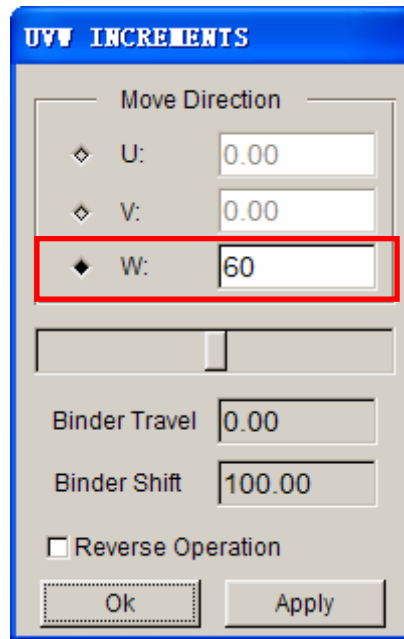

Figure 31 UVW Increments dialog box

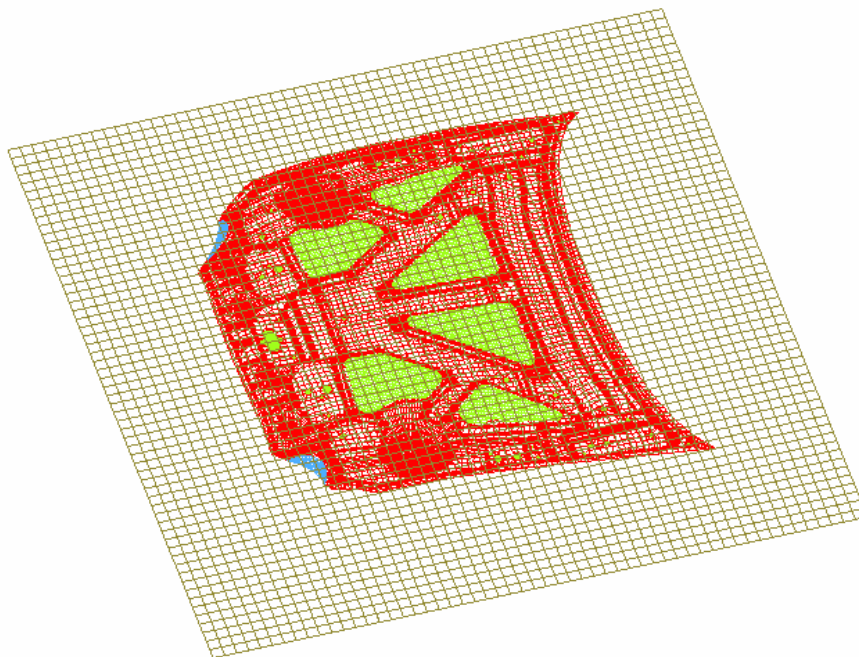

Figure 32 Mesh Binder Surface

CREATE ADDENDUM

1. Select **DFE→Addendum** from the menu bar, as illustrated in Figure 33.

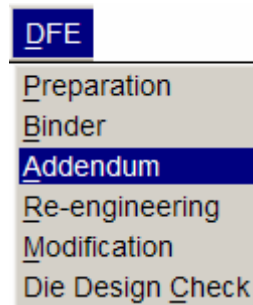

Figure 33 DFE menu

Create Master Profile

1. Click **New** button to create a new profile, as illustrated in Figure 34.
2. Select the Profile type 3 in the **Master Profiles** dialog box, as illustrated in Figure 35.
3. Click **OK** button to exit the **Master Profiles** dialog box.

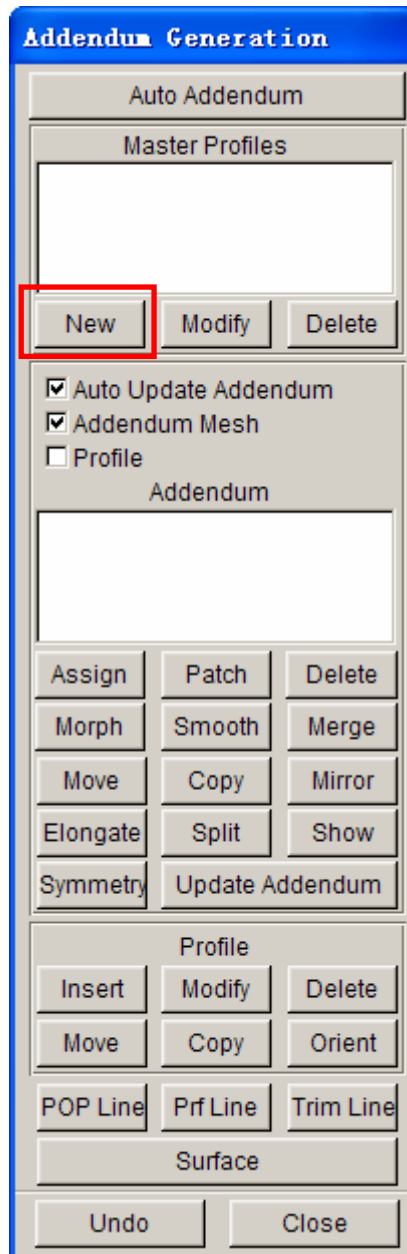

Figure 34 Addendum Generation dialog box

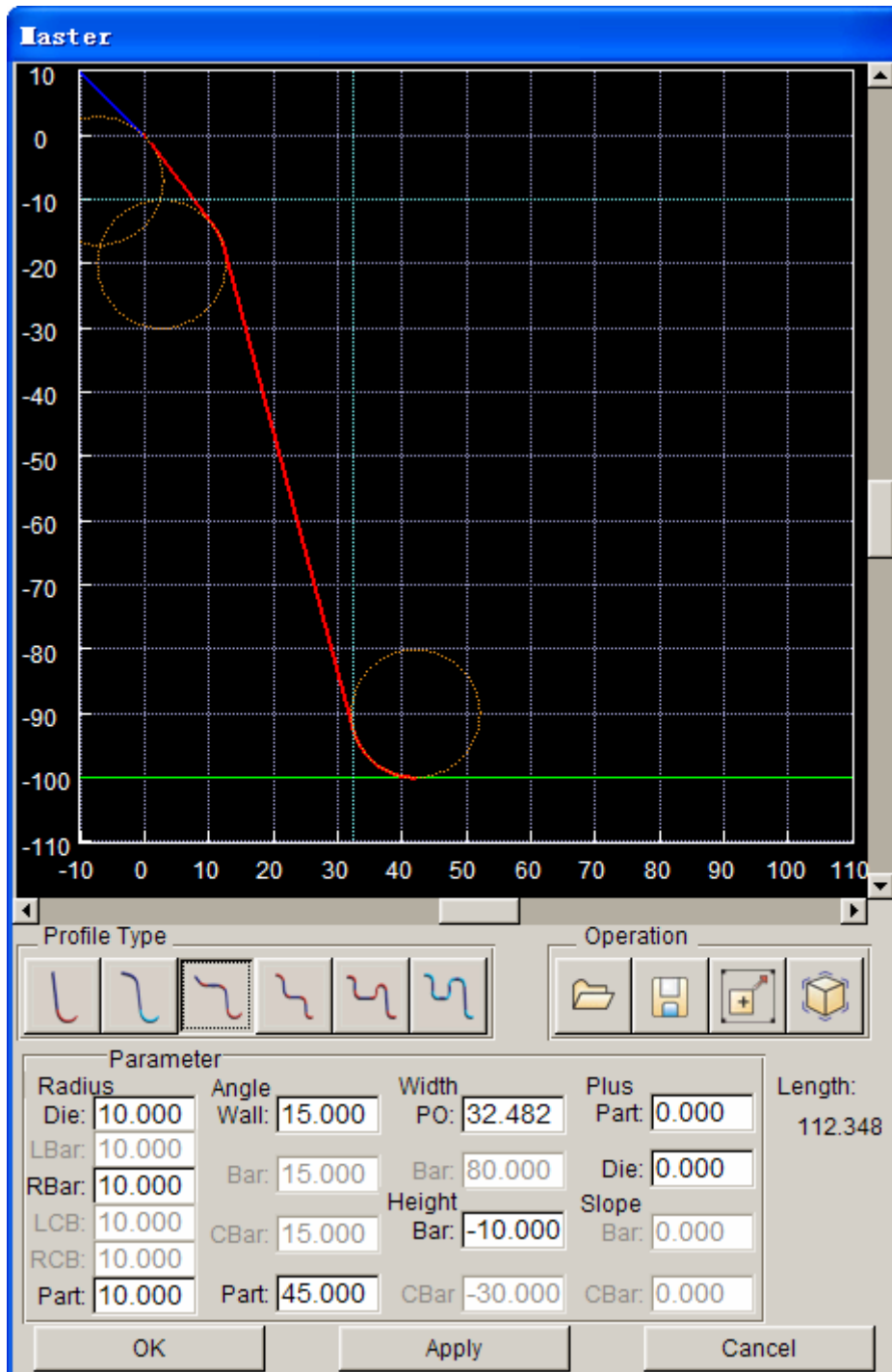

Figure 35 Master profile dialog box

Insert Addendum

1. Click **Assign** button in the **Addendum Generation** dialog box, as illustrated in Figure 36
2. Select the addendum type **OUTER** in the **Insert Addendum** dialog box, as illustrated in Figure 37.

3. Toggle off the **By Segment** option, following by clicking **Apply** button to generate the addendum.

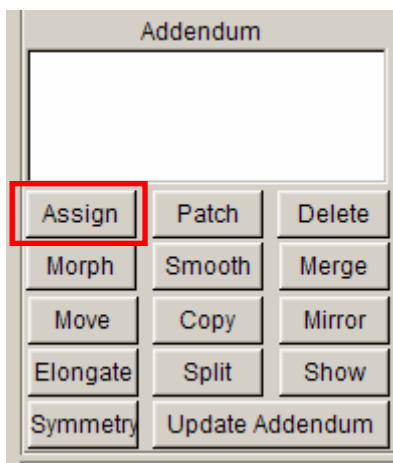

Figure 36 Addendum Operation

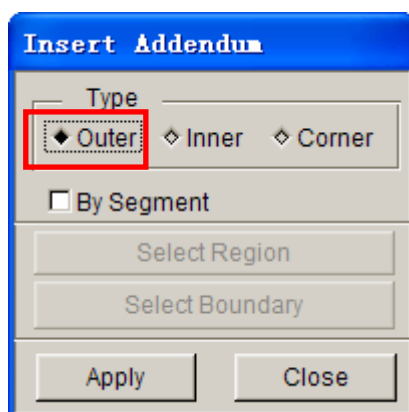

Figure 37 Insert Addendum

4. The addendum has been generated, as illustrated in Figure 38.

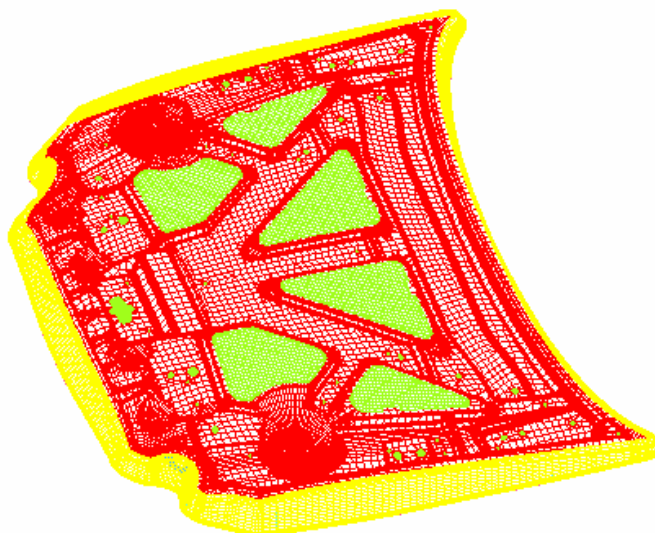

Figure 38 Generation of addendum

5. Click the **Close** button to exit the **Insert Addendum** dialog box.

Smooth Addendum

1. Click **Smooth** button in the **Addendum Generation** dialog box, as illustrated in Figure 39.
2. Toggle on the **POP Line** option as illustrated in Figure 40.
3. Click **Apply** button to display the **Smooth** dialog box illustrated in Figure 41.
4. Toggle on the **Through Fixed Points** option.
5. Select points as illustrated in Figure 42, following by pressing the **Preview** button in the **Smooth** dialog box.
6. Click **Apply** button to accept the smooth result.
7. Click **Ok** button to dismiss the **Smooth** dialog box.
8. Repeat the step 2-7 to smooth POP Line of the other region.
9. Click **Close** button to dismiss the **Smooth Addendum** dialog box.

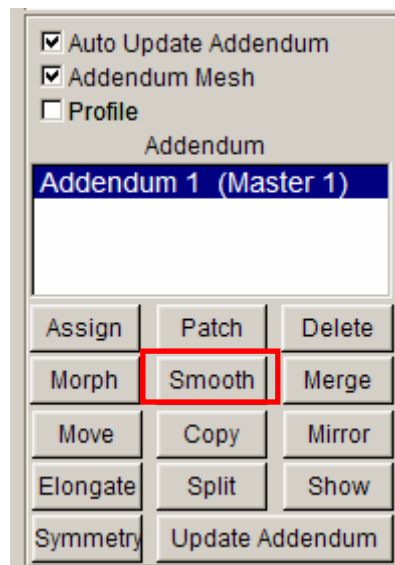

Figure 39 Addendum Operation

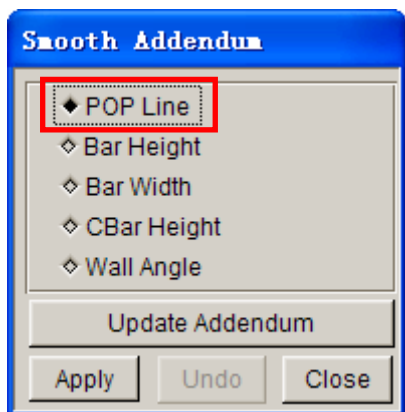

Figure 40 Smooth Addendum dialog box

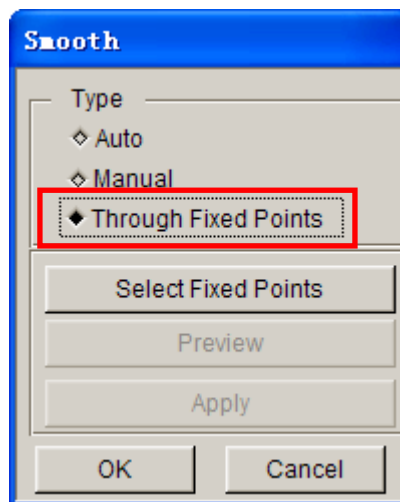

Figure 41 Smooth dialog box

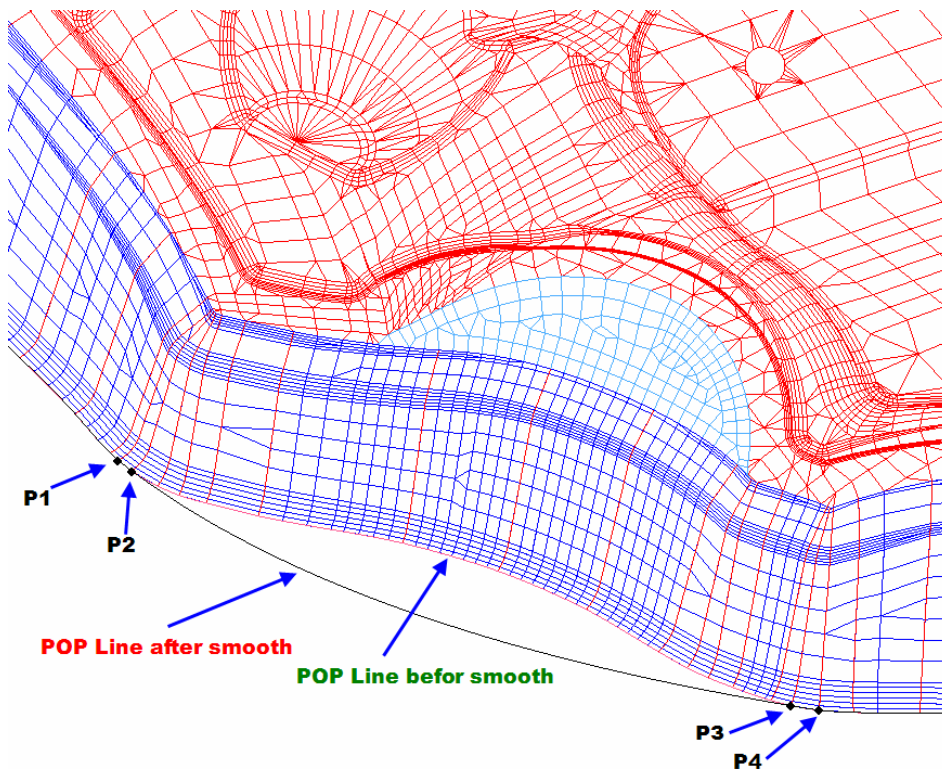

Figure 42 Smooth Addendum

Create Addendum Surface

1. Click **Surface** button in the **Addendum Generation** dialog box. The surface of the addendum has been generated, as illustrated in Figure 43.
2. Click **Close** to dismiss the **Addendum Generation** dialog box.

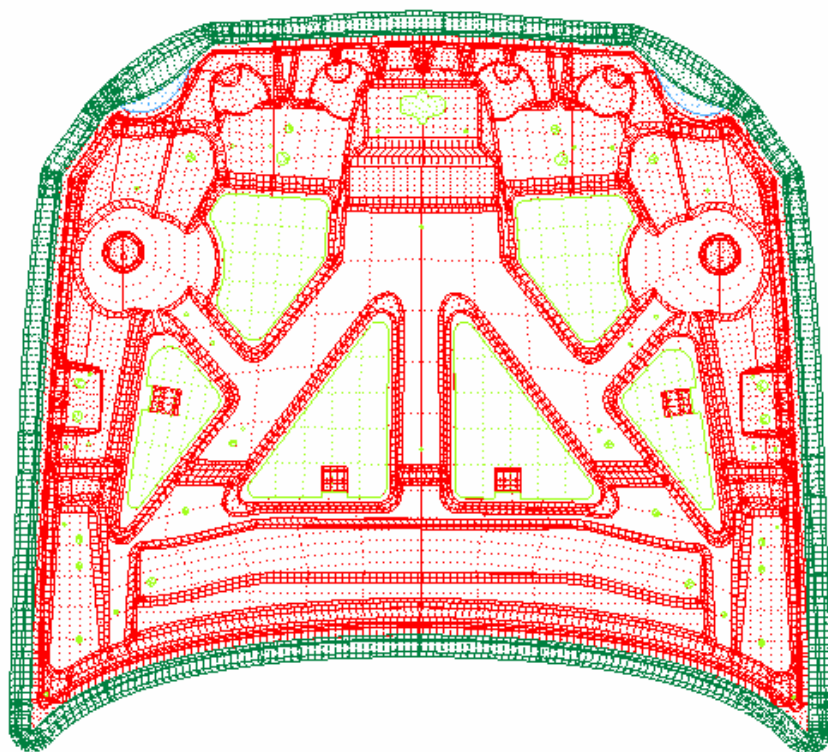

Figure 43 Generate Surface of the Addendum

BINDER TRIMMING

1. Select **DFE→Modification** from the menu bar, as illustrated in Figure 44.

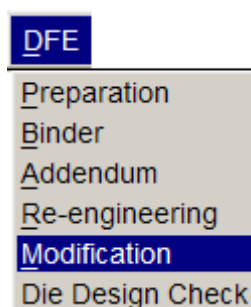

Figure 44 DFE menu

2. Select **Binder Trim** function in the **DFE Modification** dialog box, as illustrated in Figure 45.

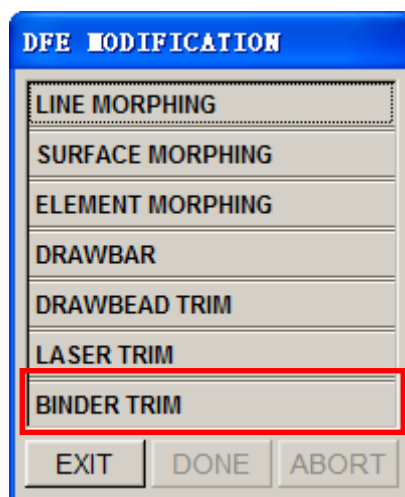

Figure 45 DFE Modification menu

3. Toggle on all the parts except **PROFILE** using the function provided in **Part Turn on/off** icon from the **Icon bar**.
4. Select the boundary type: **Outer**. Toggle off checkbox of Surface in the **Display Options** dialog.
5. Click **Select** button in the **Binder Trim** dialog box, as illustrated in Figure 46. The **Select Line** dialog box illustrated in Figure 47 is displayed.
6. Select the line illustrated in Figure in 48.
7. Click **Ok** button to confirm the selection.
8. Click **Apply** button in the **Binder Trim** dialog box, a **Dynaform Question**

dialog box is displayed (Figure 49), and the selected line is highlighted.

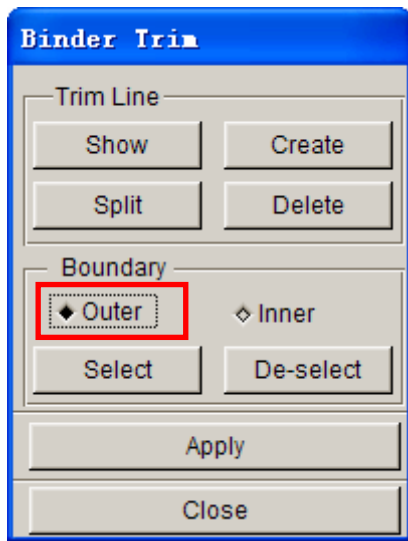

Figure 46 Binder Trim dialog box

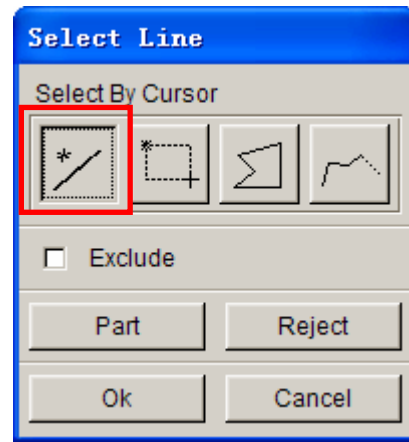

Figure 47 Select Line dialog box

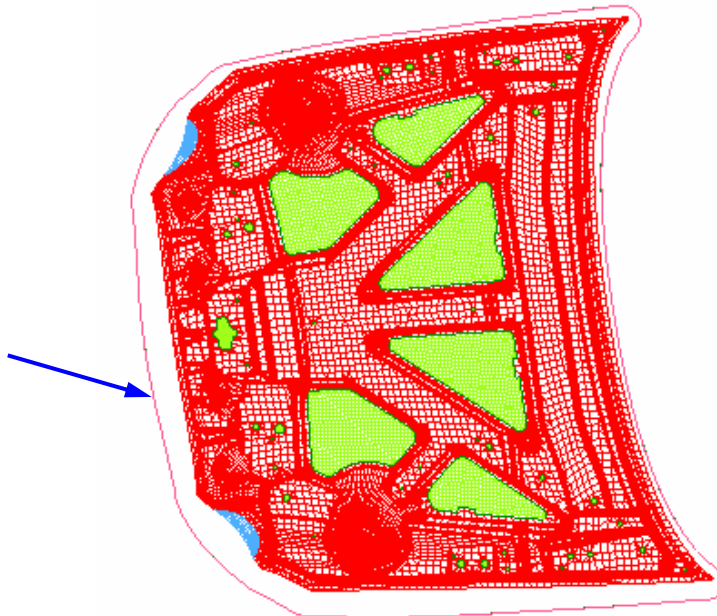

Figure 48 Binder Trim Line

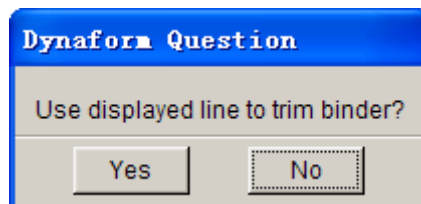

Figure 49 Dynaform Question dialog box

9. Click **Yes** button to confirm the selection. The binder is trimmed as illustrated in Figure 50.
10. Click **Close** button to dismiss the **Binder Trim** dialog box.

11. Click **EXIT** button to dismiss the **DFE Modification** dialog box.
12. Save your database.
13. The die face generation is complete, as illustrated in Figure 51.

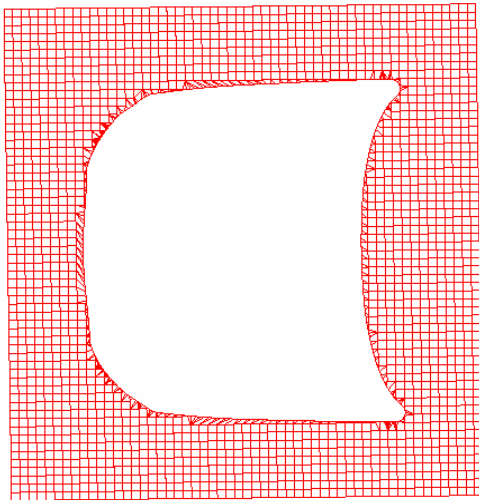

Figure 50 Binder after Trimming

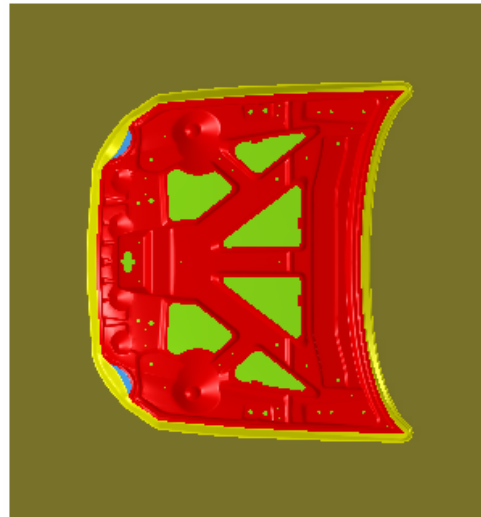

Figure 51 Generation of die face

UNFOLD FLANGE

Boundary of unfolded surfaces will be used to generate **Trim Line**.

1. Select **DFE→Preparation** from the menu bar, as illustrated in Figure 5.
2. Select **Unfold Flange** function in the **DFE Preparation** dialog box, as illustrated in Figure 52.

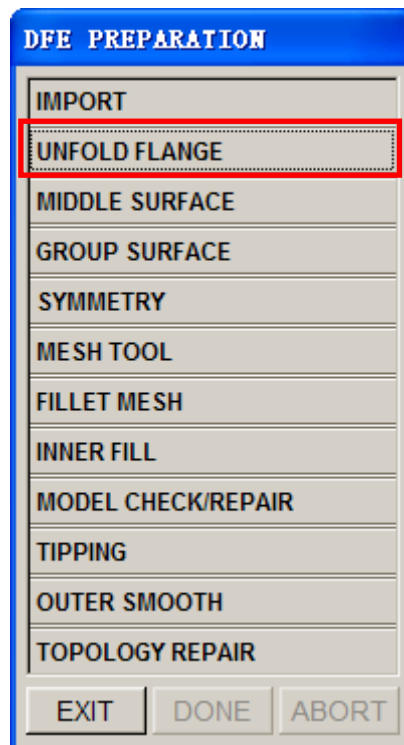

Figure 52 DFE Preparation dialog box

3. The **Select Surfaces** dialog box illustrated in Figure 53 is displayed.
4. Use rotational and zooming tools to zoom out the region as illustrated in Figure 54.
5. Select the flange surfaces as illustrated in Figure 55.

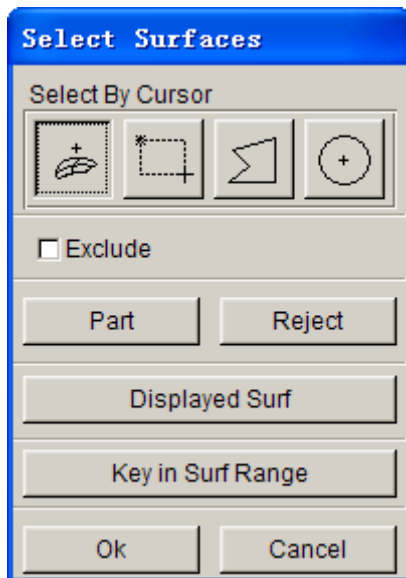

Figure 53 Select Surface dialog box

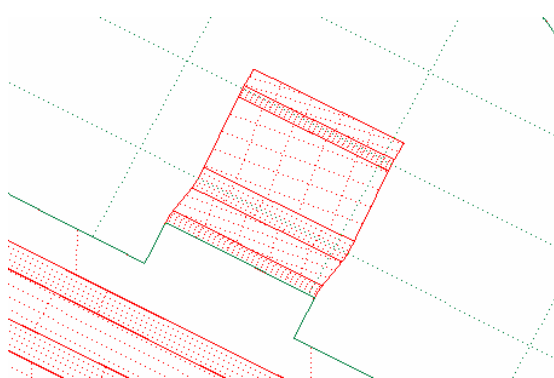

Figure 54 Flange surfaces

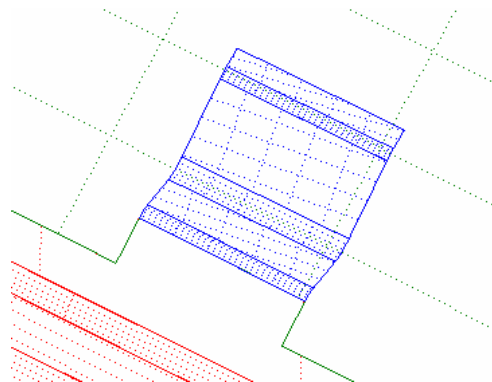

Figure 55 Selected flange surfaces

6. Click **Ok** button to confirm selection.
7. The **Select Option** dialog box illustrated in Figure 56 is displayed.
8. Select **Free Unfold** from the dialog box.

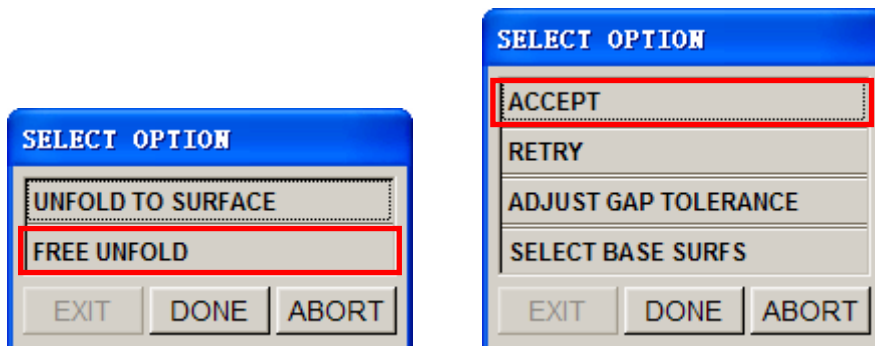

Figure 56 Select Option dialog box

9. Click **Accept** to accept the base surfaces and the unfold line, as illustrated in Figure 57.
10. Click **Ok** to accept bend angle: 0° , as illustrated in Figure 58.
11. Click **Done** button to complete the unfolding operation, as illustrated in Figure 59.

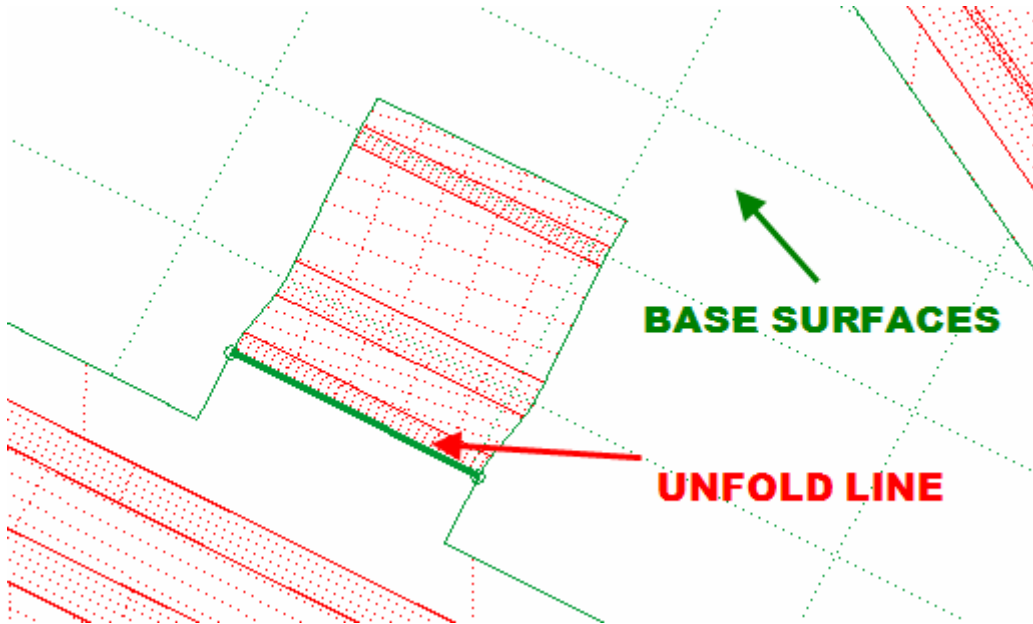

Figure 57 the Base Surfaces and Unfold Line

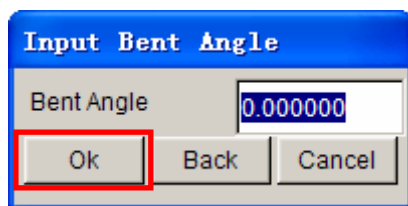

Figure 58 Input Bent Angle dialog box

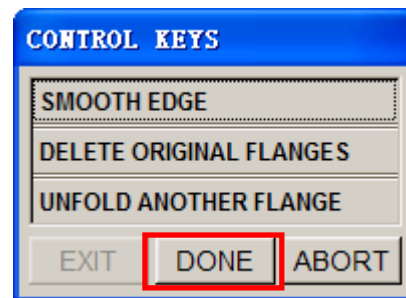

Figure 59 Control Keys dialog box

12. The flange surfaces have been unfolded, as illustrated in Figure 60.
13. Repeat step 2-11 to unfold the remaining flanges.
14. Click **EXIT** button to dismiss the **DFE Preparation** menu.
15. Save your database.

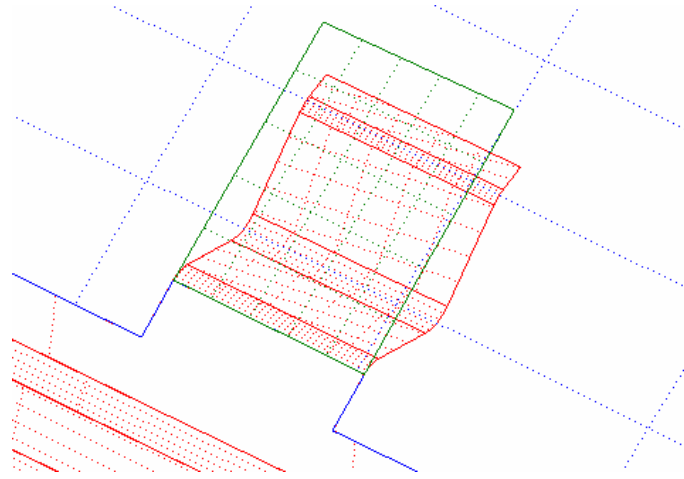

Figure 60 Unfold flange